



ENERGY & MINING DIRECTORY

Saskatchewan  Canada

ABC's mining and tunneling offerings consist of flexible fabric ducting, semi-rigid ducting, engineered inflatable stoppings, high-efficiency fans, silencers, tech services and more. Industrial ducting is manufactured for construction, aviation, military, special events and oil & gas applications. This extensive catalogue is the result of over half a century of research, innovation, and industry experience in more than 50 countries.

Products & Services Include:

- Hardline performance ducting
- Brattice
- Curtains
- Airstop
- Overhead protection
- Epass
- Ventilation Control Solutions
- Silencers
- Flexline performance ducting
- Ventilation Fan Systems
- Toughvent
- Rock Armor Geogrid Mesh

Thomas Fisher, Sales Manager
sales@abcventilation.com
1-306-653-4303



Atlas Industries Ltd. was founded in 1974 on the principles of hard work and integrity above profit. The team of skilled tradespersons, estimators, and administration work together to find solutions for our customers in the industries of mining, construction, and agriculture. They specialize in plate work, custom forming, fabrication and machining.

Products & Services Include:

- Heavy Collars for pipelines
- Stainless steel ducting and stacks
- Raisebore drilling platforms

Warren Peters, President
warren@atlasindustries.ca
1-306-244-1133

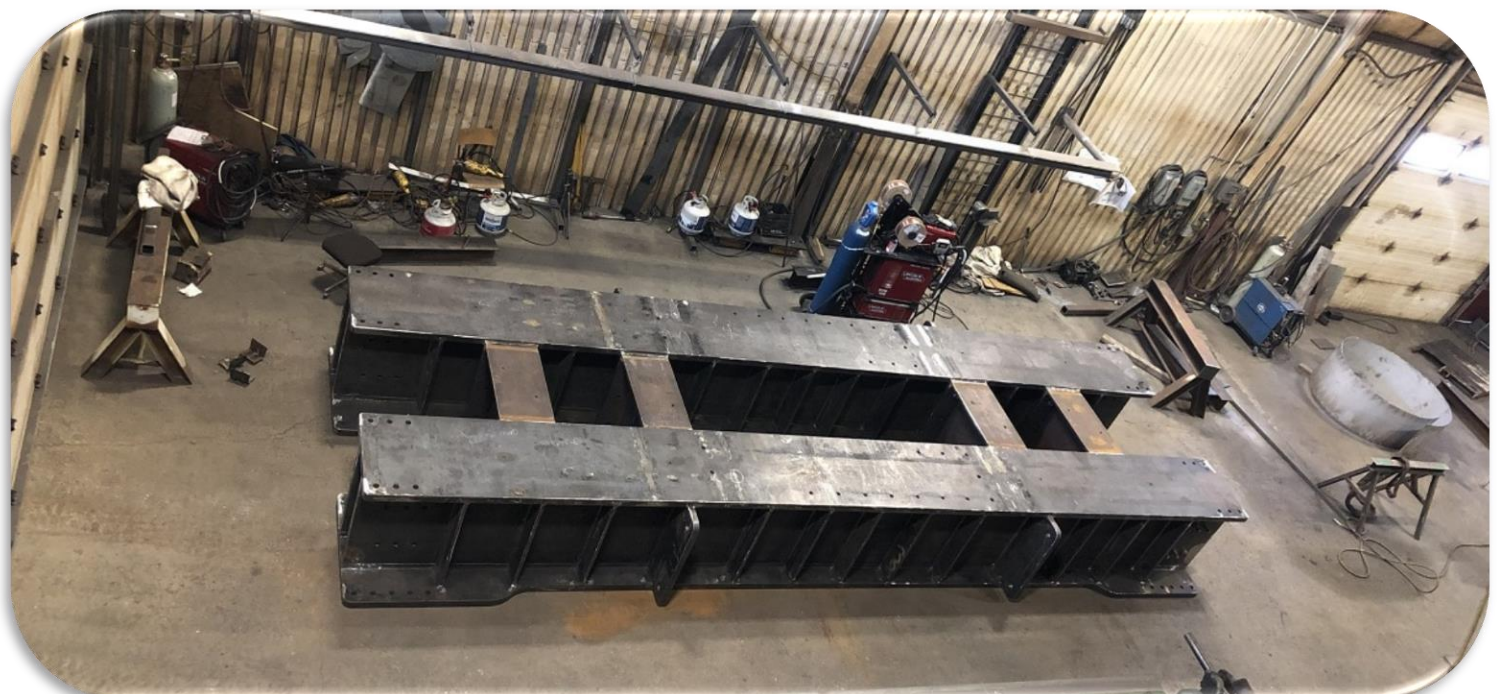

Axiom Exploration Group is an employee-owned company with its corporate head office located in Saskatoon, Saskatchewan. Established in 2011, Axiom Group is a complete consulting firm providing a diverse set of technical services within, and integrated across, each of the company's four main divisions: Exploration, Geophysics & Geomatics, Environment, and Energy Services.

Products & Services Include:

- Geological field services
- Technical reviews & reporting
- Resource modelling & estimation
- Geophysical processing & interpretation
- Synthetic aperture radar analysis
- Sentinel & aster multispectral analysis
- LiDAR
- Photogrammetry
- UAV magnets & helicopter gradiometry
- GPR
- EM
- Project approvals
- Risk Management
- EIAs
- Water resources
- ESAs
- Environmental sustainability & GHG management
- AI & Machine learning analytics
- Wellsite supervision
- HSE management

Brendan Engdahl, Business Development Manager

bengdahl@axiomex.com

1-403-978-6220

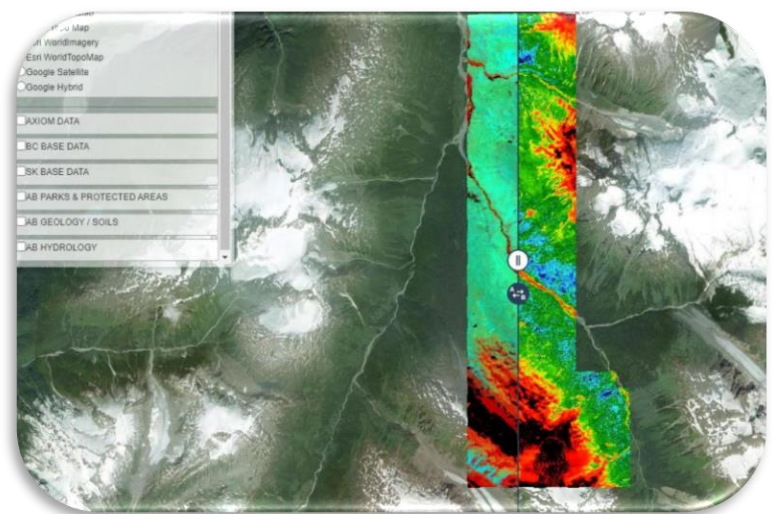



Bit Service Company Ltd.

702 46th Street East
Saskatoon, Saskatchewan S7K 0W9
www.bitservice.ca

Bit Service Company offers a wide range of quality products for the mining, construction, and materials handling industries. A locally owned Saskatchewan based company, they have been serving the mining industry since 1965.

Products & Services Include:

- Fabrication of Support equipment & accessories including bits for 2 and 4 rotor boring machines, removal tools and full assemblies.
- Repair and refurbish continuous miners, potash boring machines, road headers and undercutters

Scott Bahr, President & CEO

sbahr@bitservice.ca

1-306-653-0988

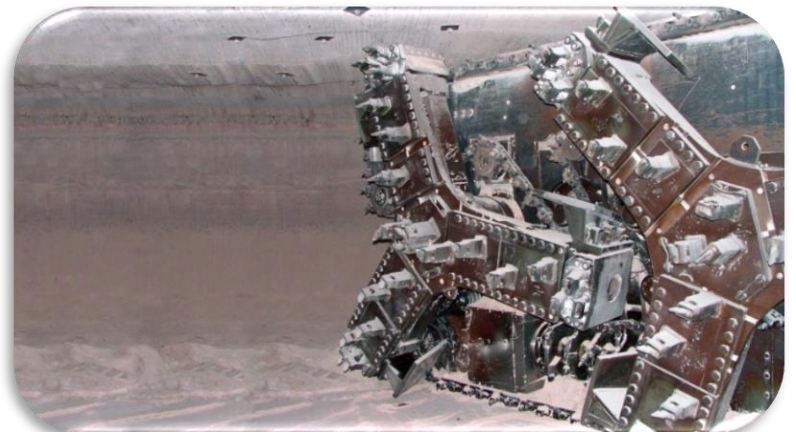
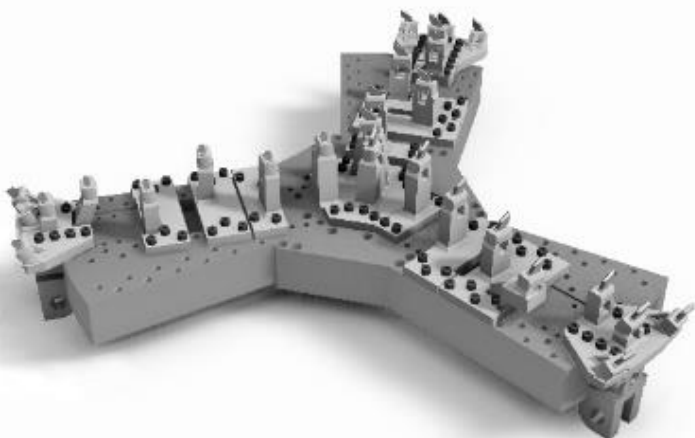



BrewNature Inc.

671 Secord Bend
Saskatoon, Saskatchewan S7V 0M7
www.brewnature.ca

BrewNature Technology is designed to help reduce the amount of organic waste that ends up in landfills, which is a major contributor to greenhouse gas emissions worldwide. The BrewNature technology works by accelerating the natural process of composting, which usually takes 5-7 months to complete, down to just 5 days. The process involves breaking down organic waste using a combination of microorganisms and aerobic conditions.

Products & Services Include:

- In-vessel composting from 1 to 15 tonnes units, water treatment and wastewater treatment.

Babak Roshani, CEO & Founder
broshani@brewnature.ca
1-306-716-6551

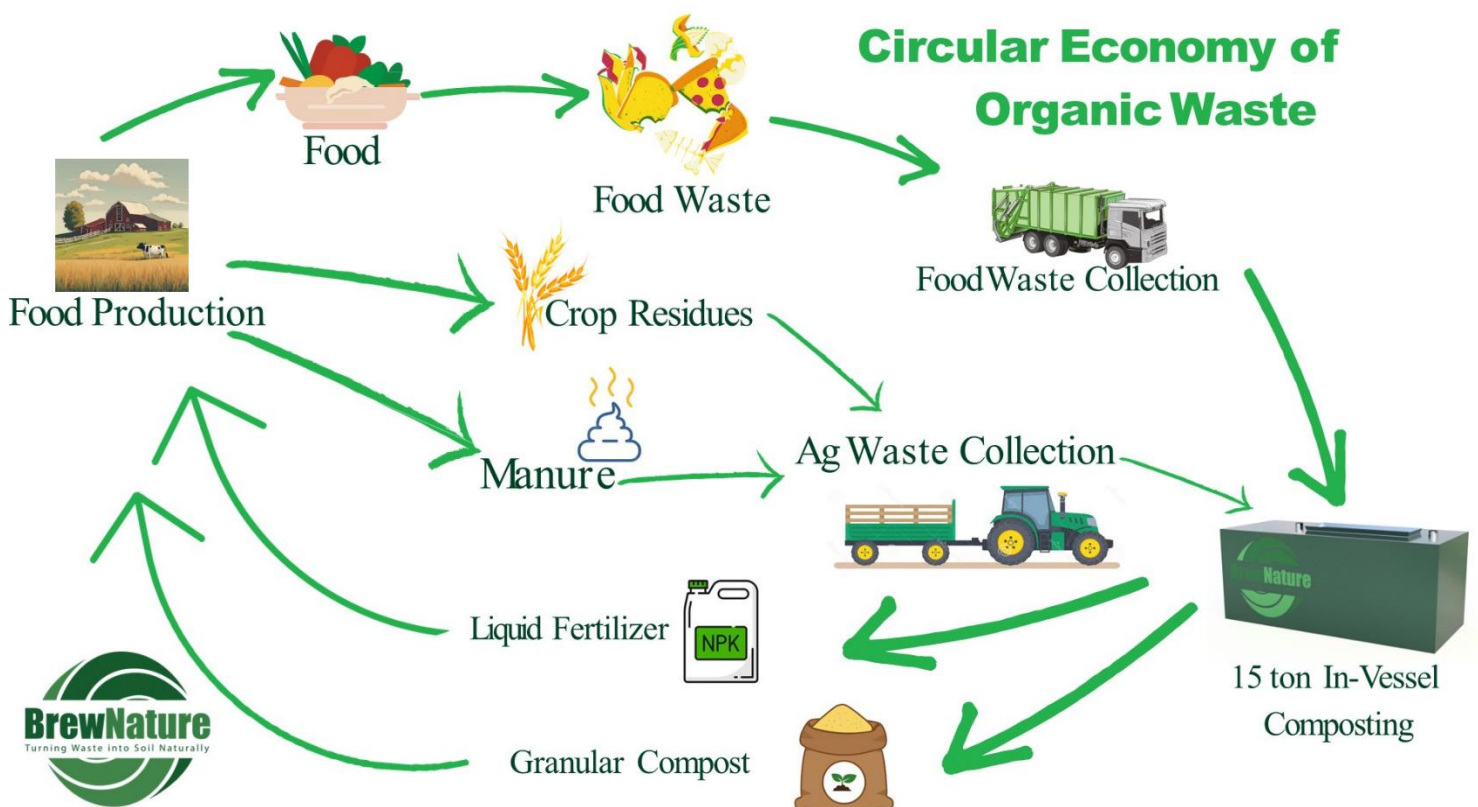



Calian Agriculture Ltd.

118 Husum Road
RM of Sherwood, Saskatchewan S4K 0A4
www.fuellock.ca

Fuel Lock® locks your fuel and allows you to view usage right from the palm of your hand. You'll know every time your fuel is accessed, and by whom – in real time. Feel confident knowing your fuel tank is secure from anywhere in the world. Fuel Lock is owned by Calian.

Products & Services Include:

- Fuel Lock™, fuel monitoring and management system.
- Fuel Lock™, Business and its free app can manage 800 employees and 500 pieces of equipment. The weatherproof enclosure has an automatic locking timer, usage reports, virtual tank monitoring and low tank level alerts.

Riley Burns, Business Development Manager

riley.burns@calian.com

306-570-7979

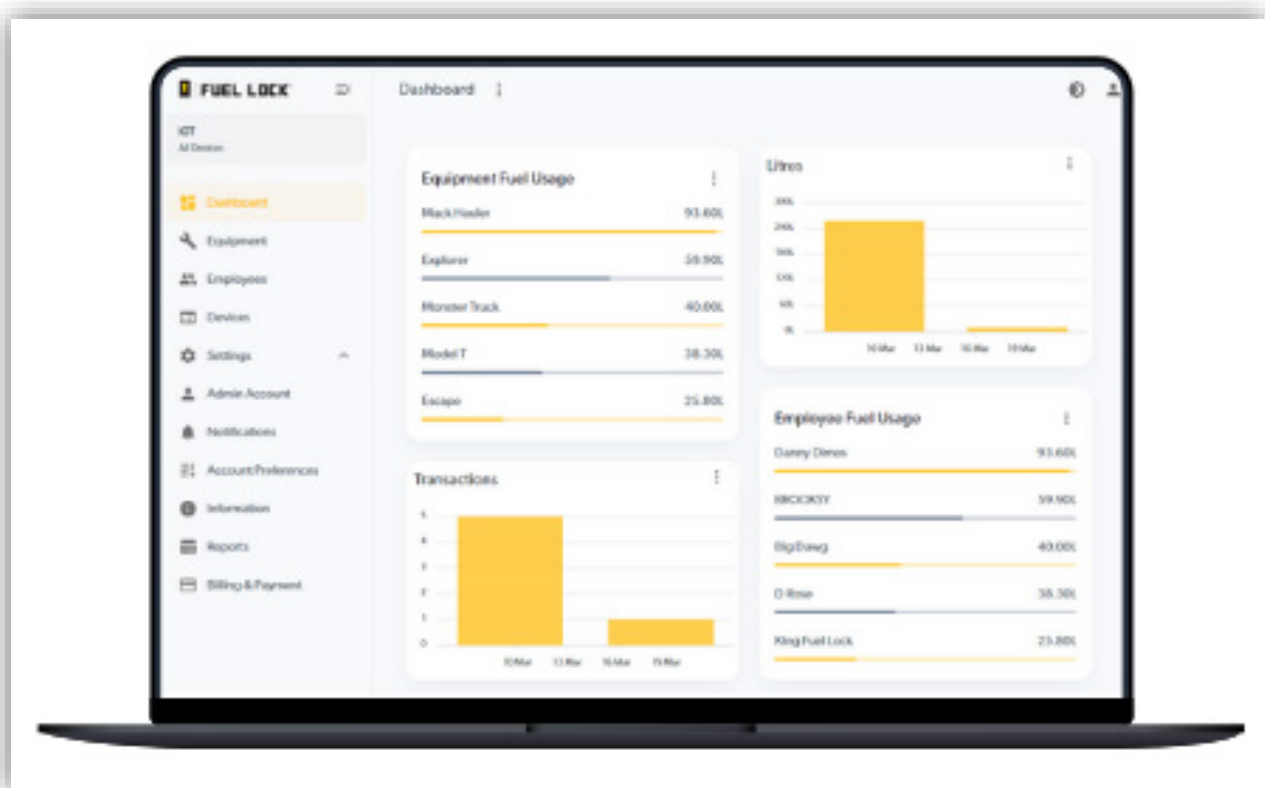
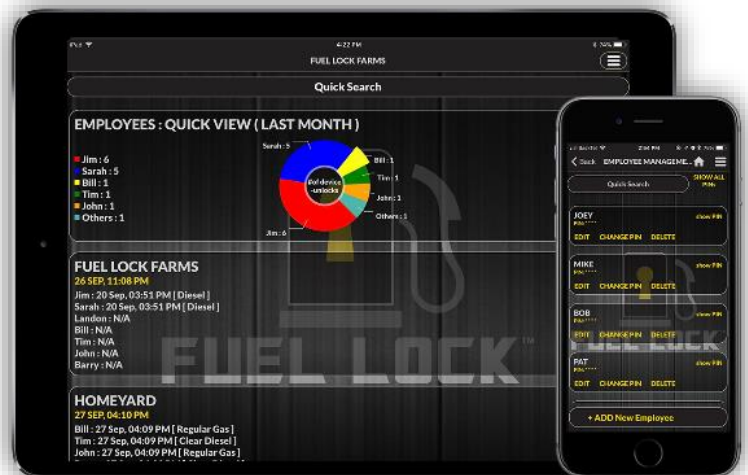

Calian Composites started in 2015 as a research branch of Calian, Advanced Technologies to investigate composite production use in large aperture antennas for the SATCOM industry. Today, Calian Composites has nearly 30,000 ft² of manufacturing space, with over 50 engineering and fabrication staff. Calian Composites is a subsidiary of Calian Ltd. which has offices around the world, including Calian, Advanced Technologies located in Saskatoon.

Products & Services Include:

- Composites-specific engineering, metrology and project planning services, right through to full component prototyping with production of final products and assemblies.
- Calian Composites currently works in the Defence, Marine/Naval and Civil markets and is expanding into Mining and Agriculture as well as general composites such as: kitting and cutting services, pattern and mold making, and rapid composite prototyping.

Michael Rennie, Director
mike.rennie@calian.com
1-306-229-8798





Cameco Corporation

2121 11th Street West
Saskatoon, Saskatchewan S7M 1J3
www.cameco.com

Cameco Corp is one of the world's largest uranium producers, a significant supplier of conversion services and one of two Candu fuel manufacturers in Canada. The company's competitive position is based on its controlling ownership of the world's largest high-grade reserves and low-cost operations. Cameco's uranium products are used to generate clean electricity in nuclear power plants around the world. The company also explores for uranium in the Americas and Australia. Cameco's shares trade on the Toronto and New York stock exchanges.

Products & Services Include:

- Uranium Mining
- Refining and conversion services

Lisa Aitken, Managing Director, Marketing
Lisa_aitken@cameco.com
1-306-956-6200





Canada North Environmental Services Ltd Partnership

211 Wheeler Street
Saskatoon, Saskatchewan S7P 0A4
www.cannorth.com

Canada North Environmental Services (CanNorth) provides a full range of environmental services and is 100% First Nations owned by the Lac La Ronge Indian Band, Saskatchewan's largest band. They provide high quality, cost effective environmental services and since 1981 have completed nearly 2,000 projects, both nationally and internationally. Their clients include the world's largest mining companies, crown corporations, government, and well-established oil and gas companies. CanNorth offers the technical skills and knowledge to deliver solutions for managing environmental risk in ways that benefit their clients, protect the environment, satisfy regulatory requirements, as well as support local communities through employment, training, and economic benefits.

Products & Services Include:

- Environmental impact assessment
- Environmental effects monitoring
- Regulatory and licensing issues
- Human health and ecological risk assessments
- Environmental site assessments
- Aquatic toxicology & fish studies
- Wildlife and vegetation assessments
- Data management and analyses
- Habitat evaluation and restoration
- Archaeology/heritage resources
- forestry

Peter Vanriel, General Manager
peter.vanriel@cannorth.com
306-652-4432
www.cannorth.com





Canada Training Group

PO Box 340
Turtleford, Saskatchewan S0M 2Y0
www.canada-training-group.ca

Canada Training Group is an international consulting firm providing training programs and consulting services to hundreds of organizations in Canada and abroad. They have built their reputation on providing hands-on critical skills training to address 21st Century problems and challenges facing their industrial clients. Since 1980, they have trained more than 25,000 people who have applied these critical skills to significantly improve safety, quality, productivity and cost control, resulting in safer, more effective workplaces and an improved bottom line for their clients.

Products & Services Include:

- Extensive training in a broad range of leadership, engineering and technical disciplines and 5 highway trailer vans that they have customized as mobile electrical training laboratories.

David Smith, President & CEO
davesmith@canada-training-group.ca
1-306-845-3200



How To Analytically Troubleshoot Complex Electrical Systems with Deductive Reasoning



Understanding Low Voltage Electrical Systems



Setting, Testing, Maintaining and Troubleshooting Electrical System Protective Devices



Electrical System Testing and Maintenance



Advanced VFD Programming and Motor Control Troubleshooting



Arc Flash & High Voltage Safety - Qualified Electrical Worker Certification



Arc Flash & Low Voltage Safety

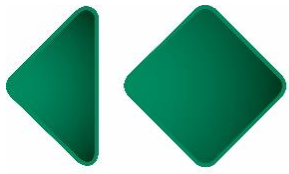

Canpotex

Inspiring Growth

Canpotex Ltd.

409 3rd Ave South, Suite 700
Saskatoon, Saskatchewan S7K 5R5
www.canpotex.com

Canpotex is one of the world's largest suppliers of potash overseas. On behalf of its shareholders, Mosaic and Nutrien, it markets and delivers Saskatchewan potash to global customers. Canpotex has corporate offices in Saskatoon, Sao Paulo, Singapore, and Shanghai. Canpotex sells and delivers Saskatchewan potash to customers primarily in Asia, South America, Central America and Oceania.

Products & Services Include:

- Marketing and delivery of potash to approximately 40 overseas countries, with majority of potash heading to Brazil, China, India, Indonesia and Malaysia.

Natashia Stinka, Director, Public Affairs
natashia.stinka@canpotex.com
1-306-931-7534



Established in 1991, **Capital "I" Industries** has been a keen leader in developing and manufacturing a full line of grader mounted and stand alone road maintenance products including grader mount road maintenance equipment suitable for all grader types. Product lineup includes one way snow plows, sod mulchers, U.S. / Canada patent state-of-the-art postless snow wings, brush and grass mowers, dozers, quick attaches and their newest additions, Capital I sloper / gravel reclaimer and road groomer.

Products & Services Include:

- Grader mount road maintenance equipment
- Exploration drilling equipment
- Oil & gas pipe handling equipment

Michelle Hart, Administration
mhart@capitali.ca
1-306-873-5437



Delco Automation Inc. is a premiere integrator of process automation and control systems. Delco Automation serves clients in North America in the following industries: water and wastewater, integrated security, ethanol, energy, mining, natural resources, oil and gas, chemicals, forestry, food processing, agriculture, environmental, and manufacturing.

Products & Services Include:

- Municipal, commercial and industrial water treatment equipment such as: reverse osmosis, nano filtration ultrafiltration, micro filtration, media filtration, biological filtration systems, membrane bio reactors, moving bed reactors, micro pollutant removal systems, containerized water treatment plants, disaster relief water treatment systems. These systems are designed to remove metals, salts, micro pollutants, bacteria, viruses, pathogens, and other contaminants.

Edward Reed, Director of Integrated Security
ereed@ipfusion.com
1-306-244-6449



Delta CleanTech Inc. is a leading provider of technology for pre-/post-combustion CO₂ capture from industrial sources, enabling significant and economical reduction of greenhouse gas emissions since 2004.

Delta's goal is to deliver practical solutions to reduce greenhouse gas emissions, CO₂ utilization, and help solve the challenges of energy security and transition.

Led by a team of experts in carbon capture, Delta's customers achieve their individual carbon capture goals through precise modeling, scaling, and costing. Delta CleanTech combines its own proprietary patented technologies with a global partnership network to meet aggressive 21st century carbon emission reduction targets.

Products & Services Include:

- Pre-/Post-Combustion Low-Cost Design Carbon Capture Technologies, LCDesign®
- Amine & Glycol Solvent Purification, Delta Reclaimer®
- Business Assessment, Planning Assessment, Conceptual, Feasibility, Pre-FEED, Mini-FEED, & Feed Studies
- Consulting services & supporting
- Training, Education, Research & Development
- Engineering Services (Troubleshooting, Optimization, Evaluation Study, Economical Analysis)

Semhar Amine, Project Coordinator
Semhar.amine@deltacleantech.com
306-352-6132

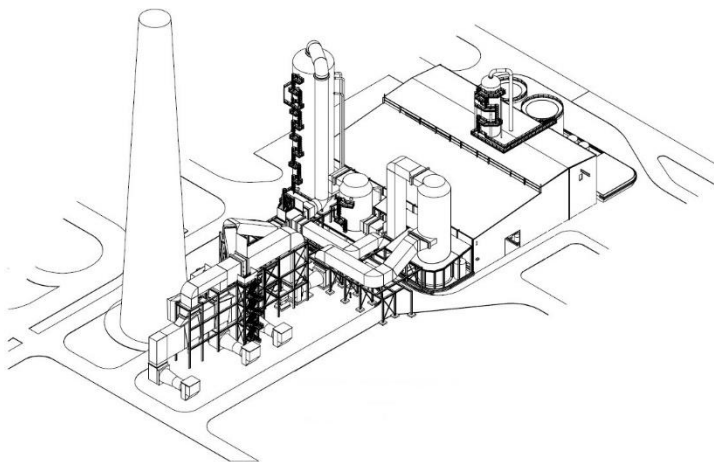



Dias Ground & Airbourne Geophysical Surveys

2131 Airport Drive
Saskatoon, Saskatchewan S7L 7E1
www.diasgeo.com

Dias delivers unique ground and airborne geophysical survey solutions to mineral exploration and other geoscience challenges through proprietary innovative technologies. Dias' induced polarization (IP) and resistivity surveys use its proprietary, efficient and effective DIAS32 system. In addition to its ground surveys and in partnership with Supracon AG of Germany, Dias also provides two highly effective airborne technologies that use SQUID-based sensors. Both ground and airborne technologies provide robust data for 3D models. Dias' head office is in Saskatoon, Canada, with locations in Vancouver, Toronto, Chili and Mexico.

Products & Services Include:

- Next-generation 3D DCIP resistivity and IP surveys using the proprietary DIAS32 system
- Ground MT/CSMAT/AMT surveys using the DIASMT system
- Full-tensor airborne magnetic gradiometry surveys using the QMAGT system
- airborne passive EM (AFMAG) surveys with the QAMT system. (Both airborne systems deliver unparalleled data in the industry due to highly sensitive low-temperature SQUID sensors.)

Jonathan Rudd, President
jonathan@diasgeo.com
1-306-700-6442





DryAir Manufacturing Corp.

400 Service Road
St. Brieux, Saskatchewan S0K 3V0
www.dryair.ca

Dryair Manufacturing Corp. is a leading manufacturer of Hydronic Heating (glycol based) equipment, serving the North American market from St. Brieux, Saskatchewan, Canada. The Dryair line of equipment focuses on construction including ground thaw, concrete cure, temporary heating, frost prevention. Dryair products are also used to provide solutions for customers in oil & gas, fire & flood restoration, and agriculture.

Products & Services Include:

- Greenthaw line of towable ground thaw units
- Central heating units (CHU's)
- Powered heat exchangers
- Explosion proof heat exchangers
- Bayonet tank heat exchangers
- Grain drying fan coils
- Desiccant dehumidifiers
- Available fuel sources are diesel, propane, natural gas & steam

Wade Wilken, VP, Sales & Marketing
wade@dryair.ca
1-888-750-1700



DynaIndustrial is a fully integrated engineering, machining and fabrication company, specializing in large custom design/build projects, industrial equipment repair and medium volume manufacturing.

Products & Services Include:

- Custom designed & manufactured equipment for mines (roof bolters, chutes, ducts, centrifuges, miner components, etc.)
- steel mills (transfer cars, furnace platforms, sideguides, etc.),
- pipe mills (pipe handling equipment, pipe double jointing lines, rotary plasma cutoffs, uncoilers, id welders, pipe collapse testers, etc.),
- oil and gas (top drive components)

Victoria Rhodes, Director of Sales
sales@dynaindustrial.com
1-306-359-7088



Dynamo is an integrated provider with engineering, manufacturing, construction, commissioning, and maintenance expertise. While each department is capable of operating independently of the others, the ability to mobilize multiple disciplines within one organization creates great depth to their team and allows them to provide cost effective solutions to their clients. Dynamo is centered on field experience and this has earned us the enviable reputation as the industry leader.

Products & Services Include:

- Engineering Services (electrical systems design, equipment specifications, bid/tender process and evaluation, procurement and project management)
- Manufacturing Services (e-houses, substations, material handling solutions)
- Construction Services (custom panel manufacturing, instrumentation & controls, plant power distribution)
- Field Services (testing, maintenance, asset management)

Doug Helmeczi, Director, Business Development

dhelmeczi@dynamogroup.ca

1-306-779-3355

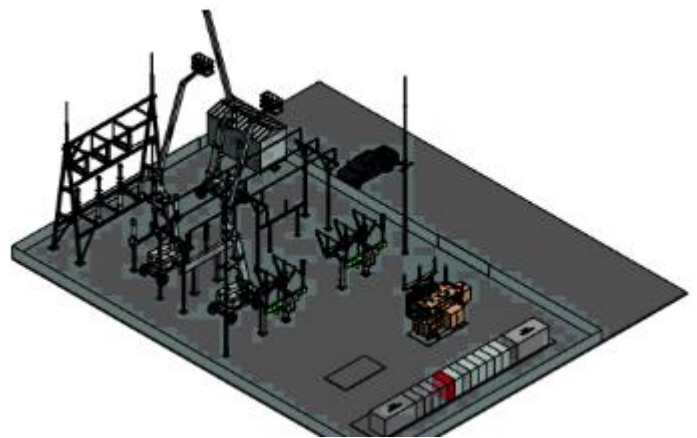

As a trusted engineering firm, **Engcomp** is driven to provide clients with innovative solutions to meet complex project needs. Proficient in overseeing and completing projects from conceptual design and feasibility studies to detailed engineering, they also specialize in risk & decision analysis, cost estimating, and project planning. Engcomp provides professional services to the potash, uranium, oil and gas, pulp and paper, chemical processing, and food processing industries. Engcomp executes both greenfield and brownfield projects varying in size and complexity and are well positioned to lead the execution of small to medium scale projects from concept to completion.

Products & Services Include:

- Mining Engineering
- Risk & decision analysis
- Project management
- Mechanical engineering
- Structural engineering & assessments
- Process engineering
- Cost engineering
- Electric engineering
- Independent project review and audits

Nick Wright, VP Marketing & Technology
nwright@engcomp.ca
1-306-978-7730



Enviro Integration Strategies is sparking a mine waste revolution, focused on reducing the risk of costly and dangerous mining waste failures, finding ways to create value through mining circularity, and helping mining executives make proactive, safer decisions. The company is developing innovative software specifically designed to comply with global waste management standards and produce transparent performance disclosures. EIS will work hand-in-hand with their client's teams to reduce their waste management risks and to facilitate a shift in operating culture where resilient and responsible practices become the norm.

Products & Services Include:

- Their risk evaluation software provides governance assurance, giving you a proactive look at the quality of past work done, to know if the site is well understood, the design and analysis were rigorous enough, and if the facilities were built and are being operated according to design. Having this information in one place is critical to diagnosing gaps and developing remedial plans, to lower the potential of a facility failure.

Karen Chovan, CEO & Founder
kchovan@envirointegration.com
 1-306-270-1430

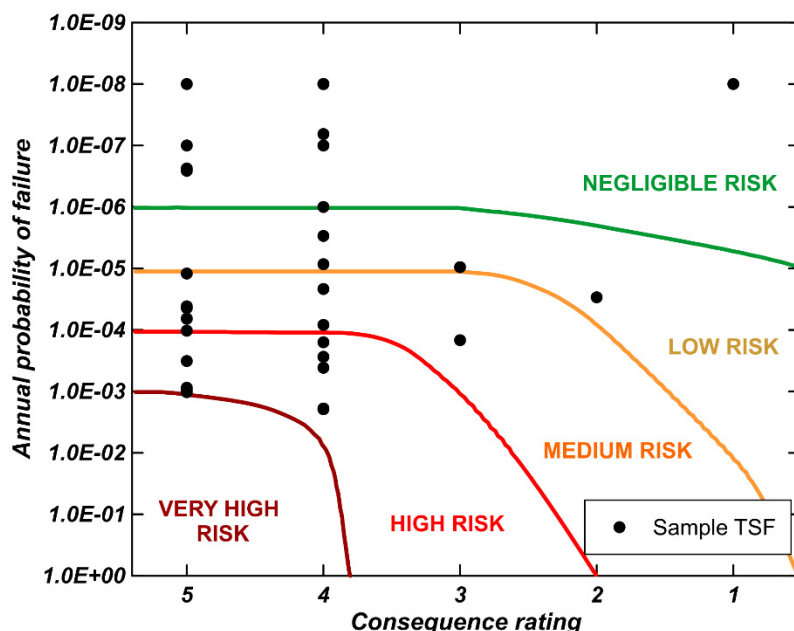
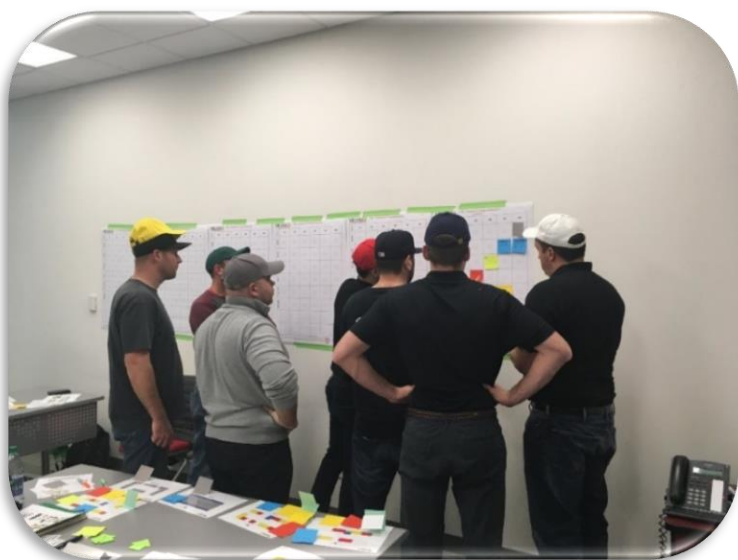



Environmental
Instruments
Canada Inc.

Environmental Instruments Canada Inc.

202-135 Robin Crescent
Saskatoon, Saskatchewan S7L 6M3
www.eic.nu

Located in Saskatoon, **EIC** has been designing and manufacturing radiation measuring instruments for mines and industry, emergency responders and radon mitigators for over 20 years. EIC also provides operational radiation safety support and consulting services to the uranium mining industry and custom designs and builds radiation measurement systems.

Products & Services Include:

- Radiation safety instrumentation
- Radon sniffers
- Gamma detectors
- Portable sample counters
- WebRad (an online radiation data management system)

Kai Kaletsch, CEO
admin@eic.nu
1-306-974-6055





ENVIRONMENTAL
MATERIAL
SCIENCE INC.

Environmental Material Science Inc. (EMS)

3038 Faithful Avenue
Saskatoon, Saskatchewan S7K 0B1
www.ems-inc.ca

EMS provides hardware and software services that allow for companies to monitor and reduce soil hydrocarbons as well as monitor carbon sequestration, and greenhouse gas emissions. EMS has been in business since 2019 and is currently operating across AB and SK. EMS uses a data-driven approach to detect and treat hydrocarbon contamination. They place remote sensors into the ground and the data is livestreamed every 30 minutes to a dashboard. The data is analyzed and a biolodestone is formulated to determine a tailored blend of macro and micronutrients. This accelerates the microorganism activity tenfold for a quicker remediation time. The nutrients are inserted into the soil using a solar-powered, remote-operated compact (2'x3'x3') Distributor that does not require water tanks or generator.

Products & Services Include:

- SoilSense
- Distributor

Jonathan Reid, Vice President, Business
Development
jonathanreid@ems-inc.ca
306-380-0545



Fortis Mining Engineering & Manufacturing offer specialized services designed for the mining industry. They have three divisions including mining, custom metal fabrication (CWB) and machining. There is also an engineering team to support the group. The combination of these teams allows Fortis to provide their customers with a complete solution to their project needs. The mining division also performs diamond drilling, mine development, civil tunneling, mine rehabilitation and dewatering, road header operation, civil and mine construction including underground construction, artificial ground freezing, mine operation, project supervision, small shafts, head frames, and shaft collars.

Products & Services Include:

- Specialized services for the mining industries, custom metal manufacturing and machining industries.

Kane Kuiack, Project Manager
kkuiack@fortiscorporation.com
1-306-242-4427

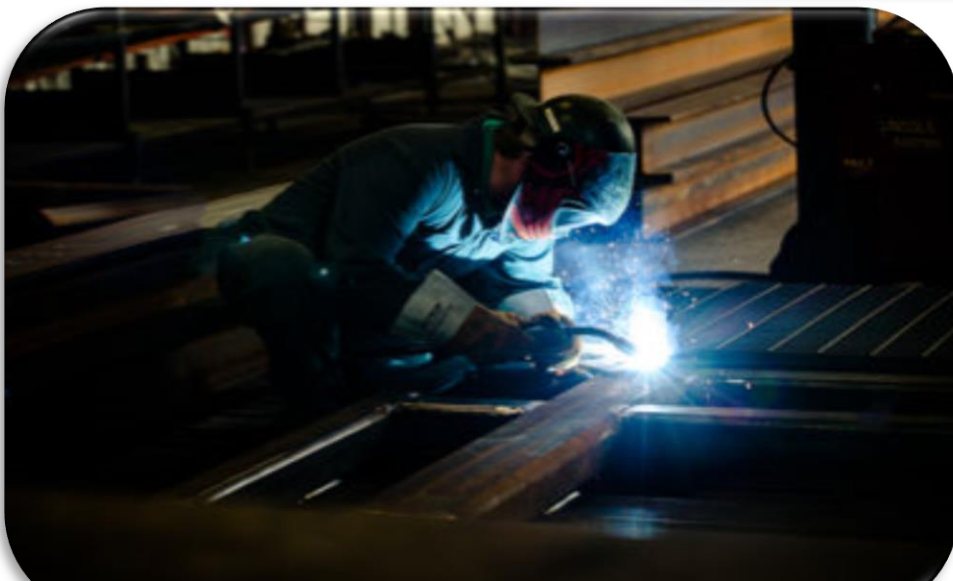



G&S Sales Ltd.

703 Saskatchewan Ave
Dilkie, Saskatchewan S0G 1C0
www.watermasterpumps.com

G & S Sales Ltd. manufactures and distributes the Watermaster Floating Pump along with its accessories. The Watermaster Floating Pump is a lightweight reliable self priming water pump that floats. It operates with an efficient heavy duty 5 horsepower, 4 cycle engine and will pump to a height of 30' uphill, 3,000' on level and up to 700 imperial gallons per minute. The large inlets and specially designed impeller allow the pump to easily handle almost any liquid from water to sludge. This product is ideal for drainage, irrigation, agriculture, construction, emergencies, mining, and oil fields.

Products & Services Include:

- Self-priming floating pump

Greg Tait, Owner
info@gssales.ca
1-306-488-4334





Graham Group

875 – 57th Street East
Saskatoon, Saskatchewan S7K 5Z2
www.graham.ca

Graham Group is an employee owned construction solutions provider with over eight decades of experience delivering exceptional project outcomes. They provide general contractor, design-build, construction management, public-private-partnership (P3) and integrated project delivery (IPD) services to the commercial, industrial and infrastructure sectors. With a proven track record of superior performance and an unwavering commitment to achieving the highest safety standards, they have grown to become one of Canada's largest construction companies with the resources, capacity and expertise to undertake and successfully deliver projects of every scope, scale and complexity.

Products & Services Include:

- Construction services across three different sectors (commercial, infrastructure & industrial)

Lynda Keebler, Executive Assistant
lyndake@graham.ca
1-306-934-6644





GreenStem Technology Corp

10-401 Pakwa Place
Saskatoon, Saskatchewan S7L 6A3
www.greenstem.ca

GreenSTEM Technology is a bio-Tech, Bio-remediation company.

Products & Services Include:

- Custom solutions to the petroleum and gas industries as well as agriculture
- Provide research for hire to find solutions to environmental problems

Michael Cavanaugh, Co-Founder
michael.cavanaugh@greenstem.ca
1-306-974-7836



Research For Hire @ *GreenSTEM*-YXE



Identify a Client
Driven
Challenge



Identify Potential
Solutions



Develop a Lab
Testing Budget



Find an Effective
Solution Using
Lab Trials



Scale-up then
Test on a Field
Site



Compare with
Other Sites



Collaborate for
Synergistic
Treatments



Share Publicity



Client gets Early
Access to New
Technology



Greenwave Innovations

649 Solomon Cres, Unit B
Regina, Saskatchewan S4N 6H9
www.greenwaveinnovations.ca

Greenwave Innovations is an industry leader in providing energy management solutions and services within all types of buildings across Canada. Their data-driven approach utilizes permanently installed electrical, natural gas and water sub-monitoring hardware in combination with our patent-protected software in order to continually reduce utility bills and greenhouse gas (GHG) emissions. They create long-term partnerships guiding customers through a sequential, ROI-based energy conservation process. With data, informed energy efficiency decisions are always made, as utility savings and emission reduction results are known prior to capital investments. At Greenwave, they enable responsible companies and public entities to produce economic-based, environmental results ... the ultimate win-win scenario!

Products & Services Include:

- Custom design, supply, install and commission non-intrusive, maintenance-free electrical, natural gas and water sub-monitoring systems.
- Access to real-time data and historical performance reports
- Consulting & Analytic Services

Dean Clark, CEO

dean@greenwaveinnovations.ca

1-306-780-0456





HCC Mining and Demolition Inc.

2615 Wentz Ave
Saskatoon, Saskatchewan S7K 5J1
www.hcc.ca

HCC has been providing underground mining services for over 20 years. They are 24% Indigenous owned and employ a 25% Indigenous workforce. They provide blasting, construction, development, rehabilitation, production and operations support, utilities installation, steel installation and shaft repairs.

Products & Services Include:

- Underground mining services (development, construction, blasting, demolition, rehabilitation, production/operations support, utilities installation, steel installation and shaft repairs)

Brennan Miller, Chief Operating Officer

bmiller@hcc.ca

1-306-652-4168





Hydraulitechs

1725 Ontario Ave
Saskatoon, Saskatchewan S7K 1S9
www.hydraulitechs.com

Hydraulitechs is an innovative design and manufacturing company specializing in the production of hydraulic machineries for hydraulic and heavy-duty repair shops. The company's engineers have extensive backgrounds in machine and hydraulic design which allow them to deliver efficient, effective and user-friendly products like: Nutbuster and disassembly table for hydraulic cylinders, automated honing machine and test rig for pumps and motors.

Products & Services Include:

- The Nutbuster (a 50,000ft/lb hydraulic torque wrench used to disassemble hydraulic cylinders)
- Chain Vise Stand
- Fully Automated Honing Machine
- Test Rig

Abe Eazadi, Sales & Marketing
mikes hydraulics@sasktel.net
1-306-683-1960

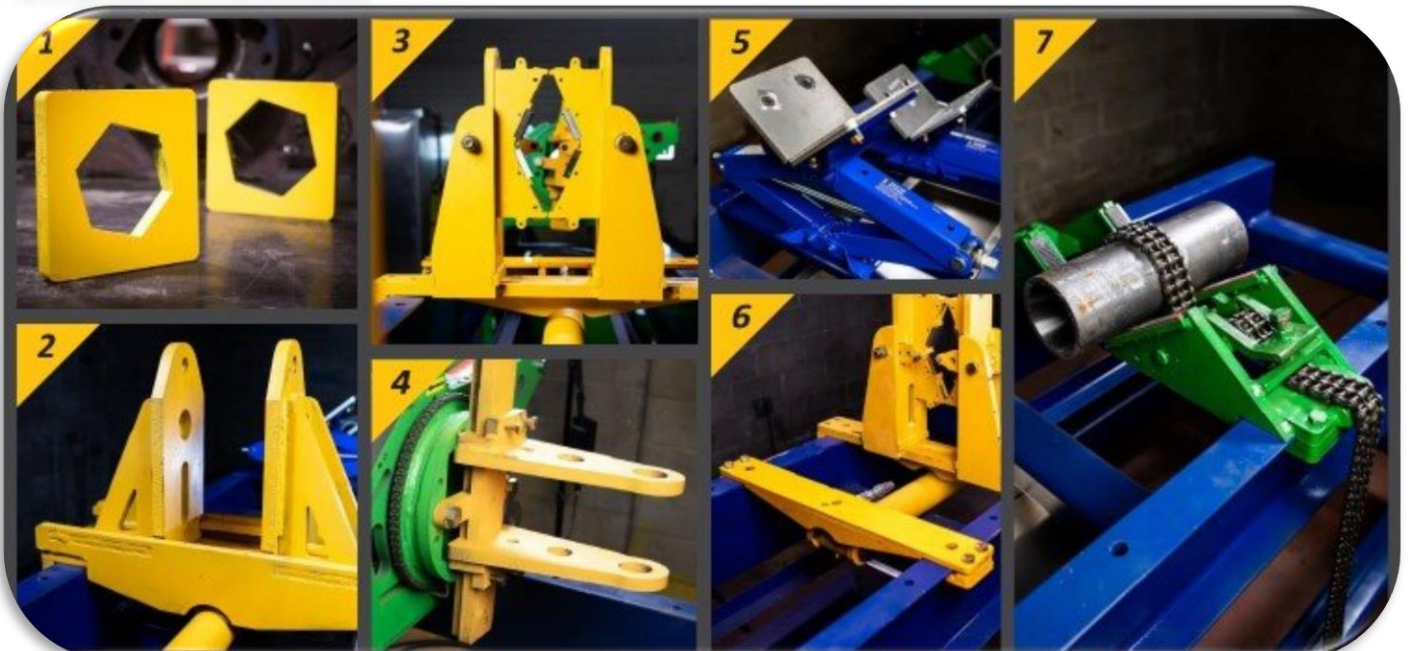
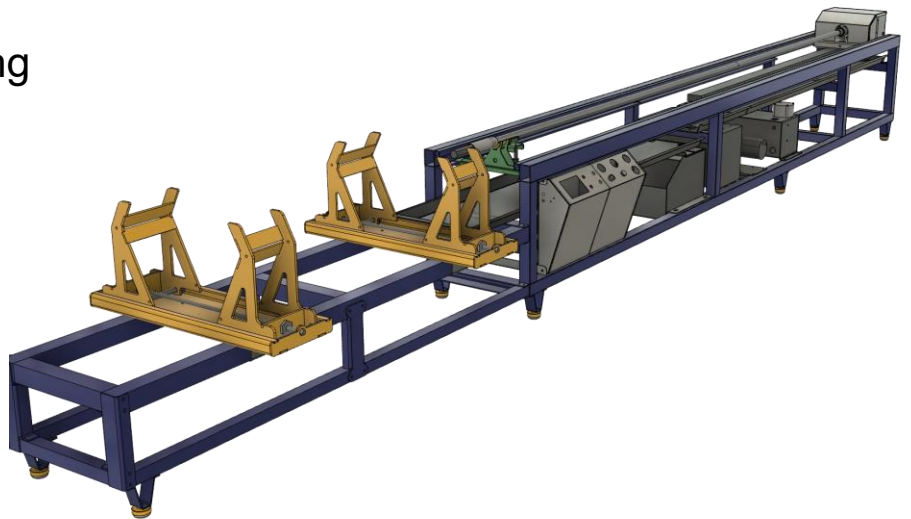

IDS offers the industry's most advanced solutions for developing optimal network-level long-term asset preservation plans. Their award-winning solutions empower engineers and asset managers to accurately assess funding needs, investigate implications of funding scenarios, and optimize the allocation of preservation budgets. In addition to working with municipalities, they can support organizations managing assets in vital sectors such as oil & gas, forestry, mining, process plants, real estate, health, and education, among others.

Products & Services Include:

- Software guaranteed to generate truly optimal long-term system-level renewal plans and long term solutions and services around four main product lines including Bridge Optimizer, Roads Optimizer, WaterNet Optimizer, and SewerNet Optimizer.

Mahmoud Halfawy, President & CEO
mhalfawy@ids.consulting
1-306-790-1415



Established in 1956, **Industrial Machine & Mfg. Inc. (IMM)** is a world class custom manufacture serving the global markets of Mining, Oil & Gas, Power Generation, Industrial and OEM's. The company is a leader in the industry by providing innovative solutions, custom manufactured components and services. IMM's 130,000 square foot full-service manufacturing facility filled with modern, world class machinery which offers custom and production machining, specialty welding and fabrication, thermal spray coatings, industrial mechanic services, site service/maintenance, OEM's, CAD/CAM, as well as engineering design and support to the heavy resource industries. IMM is COR Certified, CWB Certified, ISO9001-2015 certified and constantly strives towards Safety, Quality and Productivity standards.

Products & Services Include:

- Custom manufactured metal components
- Augers
- Centrifuges
- Compactors
- Gearboxes
- Impactors
- Miners
- Pumps
- Pipeline equipment
- U-joints
- Valve bodies
- Site service & maintenance
- Engineering design & support

Carolyn Boychuk, Sales Manager

cboychuk@indmac.ca

1-306-242-8400

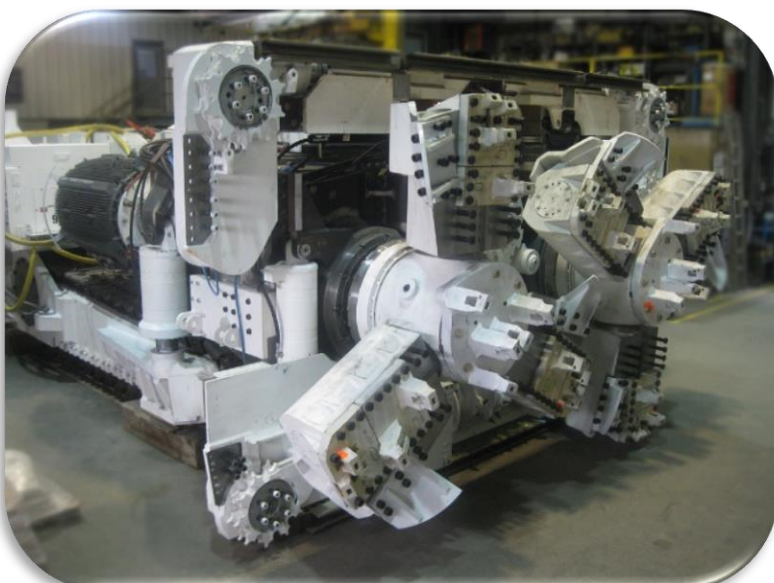

Innocorps designs and manufactures water treatment systems and technologies for decentralized, remote, reuse/recycling, residential, commercial, industrial and military applications. The company can tailor treatment and recovery to each need with key technologies including biofiltration, membrane filtration, high recovery reverse osmosis (RO) and brine concentration with their patented low temperature humidification-dehumidification (HDH) process. With advanced automation and remote monitoring, Innocorps makes it easy to provide clean water when you need it.

Products & Services Include:

- Automated water treatment for your home
- Turnkey or design-build systems for commercial, industrial and military applications

Aarya Shahsavar, President & CEO
feedback@innocorps.com
1-877-488-6861



Integral MAC is a company built on three generations of the Thiessen family. Manufacturing innovative products designed with practical solutions to oil and gas production is what they do best. Their most recent innovations are the EcoTank and EcoTube. They combine to form the most energy-efficient, cost-effective fluid storage system available today, saving up to 80% of the energy required to heat the same fluid volume in conventional tanks.

Products & Services Include:

- Building production and facilities equipment for the oil and gas industry.
- Award-winning EcoTank and EcoTube are revolutionary innovations in storage tanks and tank heating systems.
- Conventional API 12F and API 650 storage tanks up to 2500 bbl
- H₂S bubble scrubbers, and more.

Calvin Prokop, Sales Manager
calvin@integralmac.ca
1-403-998-6819

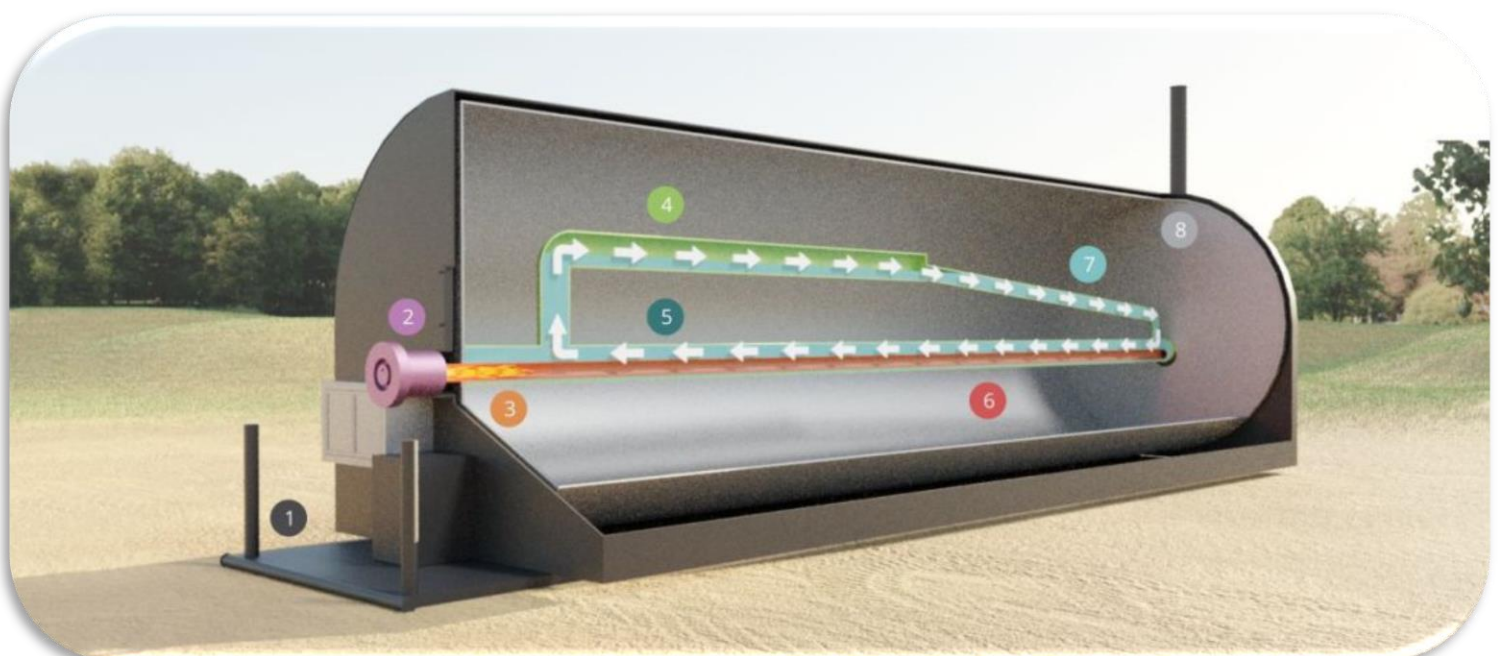

Karnalyte Resources Inc. is a junior mining company with a potash project in the exploration and development stage located in Wynyard, Saskatchewan. Karnalyte intends to construct a 2.125 million tonnes per year potash solution mining facility using a three phase modular approach. The first phase is 625,000 tonnes per year followed by two 750,000 tonne expansions. Karnalyte has obtained a bankable feasibility study, EIS approval, magnesium co-product preliminary feasibility study and is currently updating its 43-101 compliant technical report. The Company trades on the Toronto Stock Exchange under the symbol TSX:KRN.

Products & Services Include:

- A premium granular MOP potash product with minimal environmental impact. Initially a product called KCL 97 will be produced which is a low sodium, pellet form of MOP.

Danielle Favreau, Interim CEO
danielle.favreau@karnalyte.com
1-306-717-6074



Karri Howlett Consulting Inc. provides corporate strategy, finance, and risk advisement with a focus on sustainability and ESG strategies. With experience in mergers and acquisitions, including post-merger integration, Karri provides corporate strategy advisement, risk analysis, financial modelling, and due diligence for companies considering or undergoing ownership transition. Karri provides governance, financial and risk analysis advisory services for First Nations, municipal governments, and public and private businesses in a variety of industries.

Products & Services Include:

- Business strategy development
- Advisement on mergers, acquisitions, divestitures, financing, privatization, etc.
- Financial forecasting and risk management planning, Cash flow forecasting and analysis
- Post-merger integration synergy creation
- ESG Strategy

Karri Howlett, Owner
karri.howlett@sasktel.net
1-306-220-1755

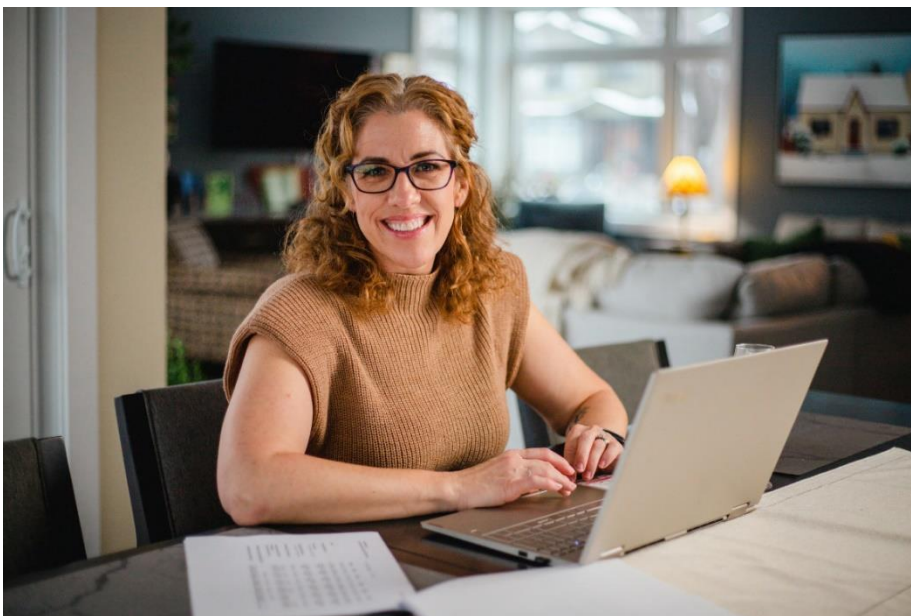



Kelly Panteluk Construction Ltd.(KPCL)

PO Box 190 | 98 Panteluk Street
Estevan, Saskatchewan S4A 2A3
www.kpclDIRTMOVERS.com

Kelly Panteluk Construction Ltd. (KPCL) is a family owned and operated heavy civil construction company completing projects across western Canada. Starting in 1953 with one man, a bulldozer and a vision, KPCL has continually expanded since inception. KPCL prides itself on helping customers solve difficult construction problems and a significant portion of its business is focused on the completion of large, technical projects that involve challenging soil conditions and intricate earth structure.

Products & Services Include:

- Construction (Heavy Civil, Road & Highway, Rail & Dam)
- Site Development (Commercial, Industrial, Residential)
- Underground Utility Installation
- Water Control & Conveyance Infrastructure
- Mining & New Mine Development
- Reclamation
- Tailings Management Facility Construction & Maintenance
- Haul Road & Site Infrastructure Development
- Overburden Removal & Pit Development
- Contract Mining
- Slurry Wall Construction
- HDPE Pipe Fusing & Installation

Riley Panteluk, Vice President
riley.panteluk@kpcl.ca
1-306-421-5867



Kvale Informatics provides a diverse selection of services to the mining, oil & gas, refining, pipeline and food industries. These include operational data strategies, PI system solutions, governance and sustainability, reliability centered operations, training & support and field data capture.

Products & Services Include:

- Engineering services
- Technology transfer
- Training
- Data acquisition and control

Kamal Narayanaswamy, Sr Engineer
kamal.narayanaswamy@meragroup.net
1-306-790-9300





Legacy Watercare Innovations

P.O. Box 664 | 17 Highway 39 East
Estevan, Saskatchewan S4A 2A6
www.legacywatercare.com

Legacy Watercare is creating a safer, cleaner water future for industry by offering accelerated standards of water clarification for wastewater treatment plants in municipal and industrial customers. They provide system products, clarification equipment and maintenance contracts to their clients.

Products & Services Include:

- An application specific, chemistry mixing system that analyzes effluent in real time, to customize chemistry prescriptions and dosing volumes before the effluent enters their novel clarification process. The clarification reactor is a fully contained, pressurized separation vessel that flows high volumes of wastewater. Legacy Water Care's process creates efficiencies, resulting in cost savings and creating safer working environments for operators with remotes monitoring and water analytics.

Ticia Heward, CEO

tlheward@legacywatercare.com

1-306-541-4653





Magnum Fabricating Ltd.

PO Box 1535 | 113 Hwy 21 North
Maple Creek, Saskatchewan S0N 1N0
www.magnumfabricating.com

Magnum Fabricating Ltd. is a metal fabrication manufacturer and welding shop located in Maple Creek, Saskatchewan. They manufacture above ground storage tanks (ULC 601, UL 142), single wall, double wall, horizontal, vertical tanks, up to 200,000 liters of volume and transport Canada in 31/a fuel tanks for transport of gas, diesel, etc. up to 4,500 liters.

Products & Services Include:

- Cattle Handling Equipment
- Oilfield Fencing
- Texas Gates
- Oil Tanks
- Fuel Tanks & Fuel Skids
- Transport Canada in 31/a fuel tanks for transport of gas, diesel, etc.

Richard Ehret, President
rmf@sasktel.net
1-306-662-2198





Major Reclaim Corp

Site 18, Comp 39, RR5
Prince Albert, Saskatchewan S6V 5R3
www.majorreclaim.com

Major Reclaim Corp is a mining services provider that has worked on six continents. They are specialists at recovering precious metals and have developed a proprietary approach and method to recover the highest amount of value from mill houses, refineries, tailings, and waste sites. Their main focus is Gold, Copper, Silver, Platinum and Palladium.

Products & Services Include:

- Using a proprietary approach to recover precious metals from the mills system.

Steve Depeel, Owner/Operator
steve@majorreclaim.com
1-306-314-0114





MAVEN
WATER & ENVIRONMENT

Maven Water & Environment

103-303 Wellman Lane
Saskatoon, Saskatchewan S7T 0J1
www.mavenwe.com

Maven Water & Environment believes in a sustainable future, where clean energy and products are produced with minimal impact to water and the environment. The mining and oil and gas sectors produce many materials critical to the advancement and application of clean energy. By empowering people and applying technology, we have developed a range of natural and powerful water treatment and source control technologies that can ensure our water resources remain safe while sourcing the materials needed for a sustainable future.

Products & Services Include:

- Assessing site-specific needs, and recommend the best combination of treatment technologies, management strategies, and source control opportunities. Their experts offer passive and semi-passive and biological water treatment technologies such as treatment wetlands (CWTS), gravel bed reactors, bioreactors (BCRs), etc. Through strategic collaborations with experts in active treatment, our toolbox spans a wide range of active technologies (e.g., reverse osmosis, ultrafiltration, lime precipitation, ion exchange, etc).

Monique Simair, CEO & Principal Scientist
monique@mavenwe.com
1-306-227-9632

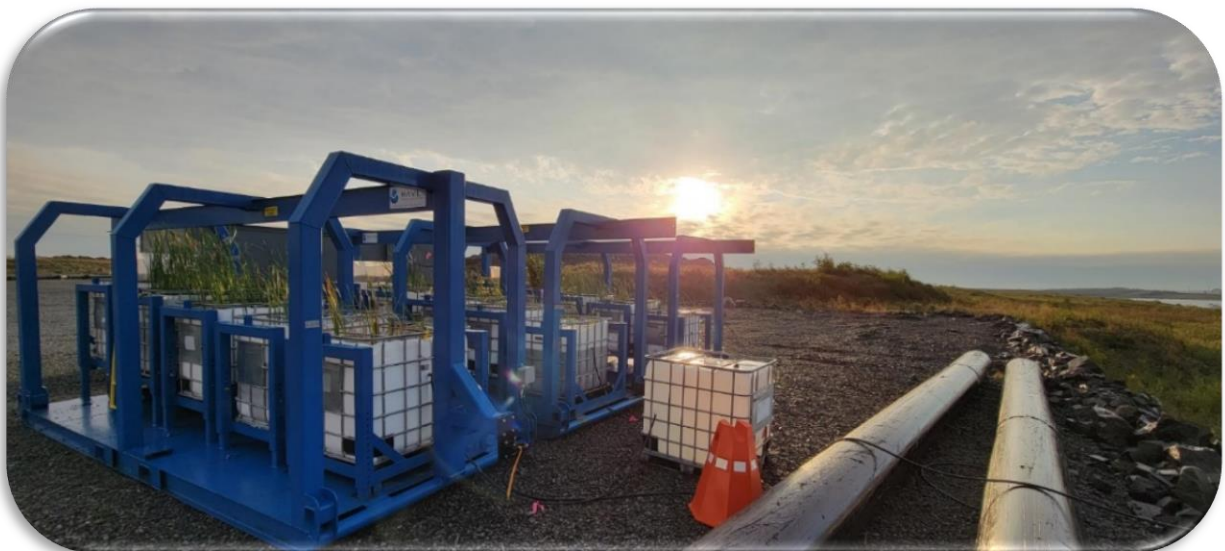



MMKL Group

5-3919 Brodsky Ave
 Saskatoon, Saskatchewan S7P 0C9
 www.mmklgroup.com

MMKL offers a range of products and services in industrial, environmental, and technology solutions. Their customers choose them for their cost-effective prices and their ability to find hard-to-find products that are not readily available in standard distribution channels. MMKL Group is committed to supporting Indigenous businesses and communities, and their partnerships with organizations like Superior Strategies help them to provide solutions that are Indigenous-owned and managed. At MMKL, they use innovative approaches to create employment opportunities in Indigenous communities. They believe in making a positive impact on society, and supporting Indigenous businesses and communities is a key part of their mission.

Products & Services Include:

- Technology for the mining industry such as preventative maintenance, safety, fire prevention, inventory management, IT PPE including gloves, hard hats, small tools and workwear.
- They also provide gas detection bio remediation fire prevention tools and suppressants.

Mark Hinz, CEO
 mhinz@mmksupply.com
 1-306-281-8544

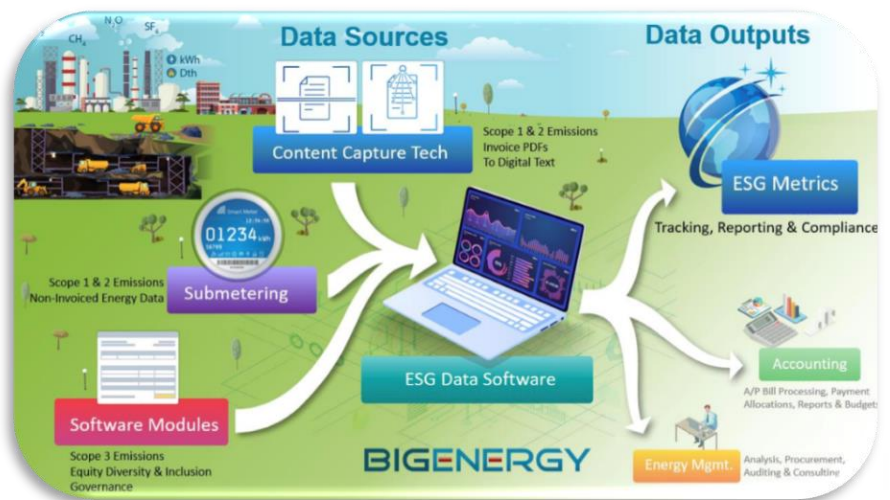



Morris Interactive
it starts with people

Morris Interactive

#106, 4002 Arthur Rose Avenue
Saskatoon, Saskatchewan S7P 0C9
www.morrisinteractive.ca

Morris Interactive is a dynamic consulting firm, based in Saskatoon, SK with regional offices located in Calgary and Fort Collins, Colorado. They work with businesses of all sizes across multiple industries including agriculture, public sector, mining, healthcare, as well as with over 100 indigenous organizations. Morris Interactive has built its reputation by delivering honest and direct feedback and delivering solid results and project outcomes for their clients. Their latest service is “Digital Transformation in Potash,” an indigenous pre-employment program.

Products & Services Include:

- Digital Transformation in Potash
- Leadership development
- Strategic planning
- Customer service
- Sales training
- Governance and board training
- Team building
- Communication
- Employee engagement
- Everything DISC programs
- Five behaviors of a cohesive team
- Certified change management
- Respectful workplace
- Staff retreats
- HR consulting
- Feasibility studies
- Health evaluations
- Pre-hire assessments
- Organizational data diagnostic programs
- LINK market services

Matthew Cew, CEO

mathew@morrisinteractive.ca

1-306-955-3006



myComply helps blue-collar industries track workforce activity and verify the presence of qualified personnel. myComply's cloud-based software and integrated IoT hardware solutions help to ensure that each worker meets specific site requirements, like proper documentation, completion of orientation, and up-to-date safety training. Ensure a 100% qualified workforce on your job sites with myComply.

Products & Services Include:

- Provides IoT hardware and cloud-based software to blue-collar industries, like construction, mining, and manufacturing. The hardware component is built to track time/attendance, manpower, control access to the site, and verify qualified individuals. The software component is utilized to ensure that all subcontractors (and their workers) have completed the proper onboarding and are vetted for site requirements like safety certifications, licenses, training, and orientation.

Rylan Spencer, Business Development,
Mining, Facilities & Energy
rylan@mycomply.net
1-306-491-7967





Norseman Structures

3815 Wanuskewin Road
Saskatoon, Saskatchewan S7P 1A4
www.norsemanstructures.com

Norseman offers ShelterSolutions in the pre-engineered building industry, specializing in steel framed fabric covered buildings. They offer turnkey solutions with services including design and engineering, manufacturing, construction, financing and documentation.

Products & Services Include:

- Solutions with services including design and engineering, manufacturing, construction, financing, and documentation.

- ShelterSolutions in the pre-engineered building industry, specializing in steel framed fabric covered buildings.

Areeb Faruqi, VP, Growth & Strategic Partners
afaruqi@norsemanstructures.com
1-306-385-2888

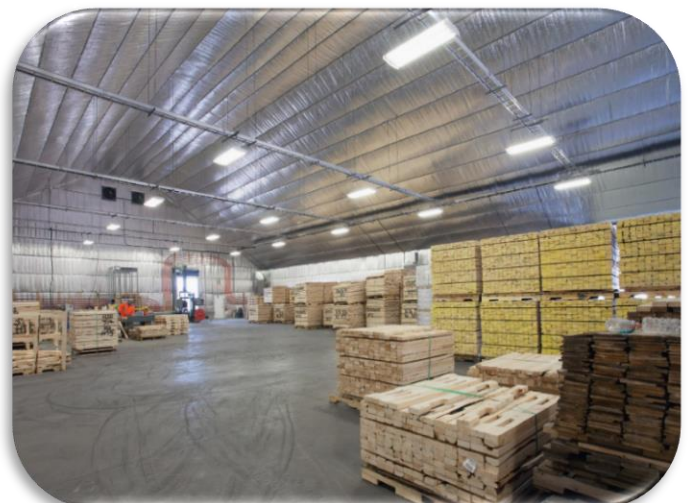

North Fringe Industrial Technologies Inc. (NFIT) is a local Saskatchewan owned and operated business focused on offering pump sales, pump service/repair, pump rentals, dredging and dewatering. The company has been focused on pumps and pump related markets and services since the start of operations in 2007.

Products & Services Include:

- Manufactured pump stations & dewatering stations
- Pump sales
- Pump/hose rentals
- Pump repairs
- Hoses
- Dewatering
- Evaporation
- Filtration
- Screen sales
- Dredging
- Pump repairs in house

Brett Cain, President
sales@northfringe.com
1-306-862-5900



North Star Systems is a hardware and software developer. Tattle Systems maximizes the use of new innovative IoT and M2M technologies, with the focus on real-time controlled remote monitoring for various liquid tanks and pressure vessels. It can be used for optimizing employee productivity, inventory levels, optimizing asset management practices and other uses.

Products & Services Include:

- Tattle system hardware & software
- Live dispatch
- Order management software
- OIL TATTLE, a controlled remote tank monitoring and data solution for oil & gas
- Custom hardware/software

Curtis Kolibab, CEO
ckolibab@northstarsystems.ca
1-306-653-0189



NORTHERN STRANDS Northern Strands

3235 Millar Ave
Saskatoon, Saskatchewan S7K 5Y3
www.northernstrands.com

Northern Strands has been supplying industry since 1970, evolving into six major divisions that offer needed tools and technical knowledge in mine hoisting and attachments, general rigging, engineered fall protection, suspended access, training and agriculture terminal maintenance. Products and services include underground mining wire rope, attachments and equipment and general rigging, crane ropes and material handling.

Products & Services Include:

- Underground mining wire rope
- Attachments & equipment
- General rigging
- Crane ropes
- Material handling

Cody Gampe, Marketing Manager
cgampe@northernstrands.com
1-306-242-7073

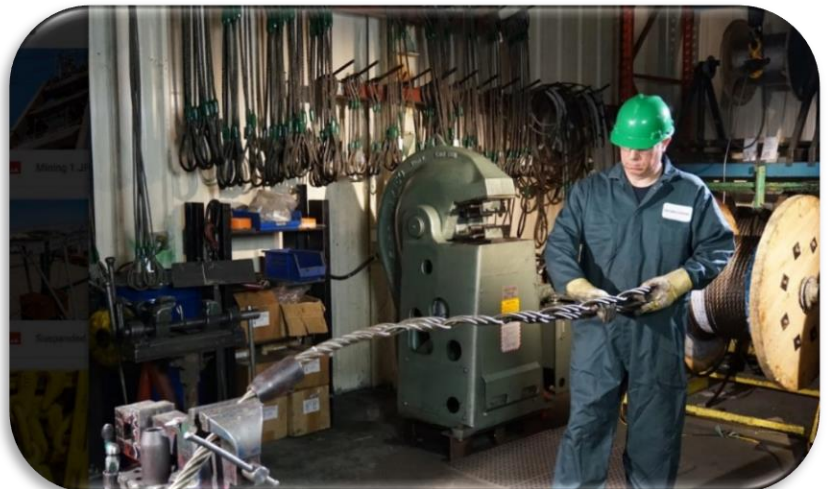



Nutrien Ltd.

122 – 1st Ave South, Suite 500
Saskatoon, Saskatchewan S7K 7G3
www.nutrien.com

Nutrien is the world's largest provider of crop inputs and services, playing a critical role in helping growers increase food production in a sustainable manner. Nutrien produces and distributes over 25 million tonnes of potash, nitrogen and phosphate products world-wide. With this capability and a leading agriculture retail network, they are well positioned to supply the needs of customers. The company operates with a long-term view and is committed to working with stakeholders to address economic, environmental and social priorities.

Products & Services Include:

- Potash
- Phosphate
- Nitrogen

Cam Baker, Director, Government & Industry Affairs

Cam.Baker@nutrien.com

1-306-933-8500



Peter Lucas Project Management places project experts who are motivated to produce results, where and when our clients need them. Our employees are permanent investments and we aim to ensure everyone feels welcomed, known, included, connected and supported in their roles.

Products & Services Include:

- Project management
- Project engineering
- Administration
- Scheduling
- Cost control
- Construction management
- Safety management
- Drafting services
- Operations support

Leah Legacy, Office & Marketing Manager
leah.lagacy@peterlucas.ca
1-306-716-9323

Get **fastest access** to the **best team** for your project.



We save you time
Reduce your recruiting, hiring and onboarding time from 10 weeks on average to just 3 weeks.



We save you work
Only meet qualified and vetted professionals that are tailored for your unique team and needs.



We find the best people
Our people are hired on what they have done, what they know, and who they are.



Our strength is diversity and inclusion
Our process limits the influence of unintentional bias while hiring.

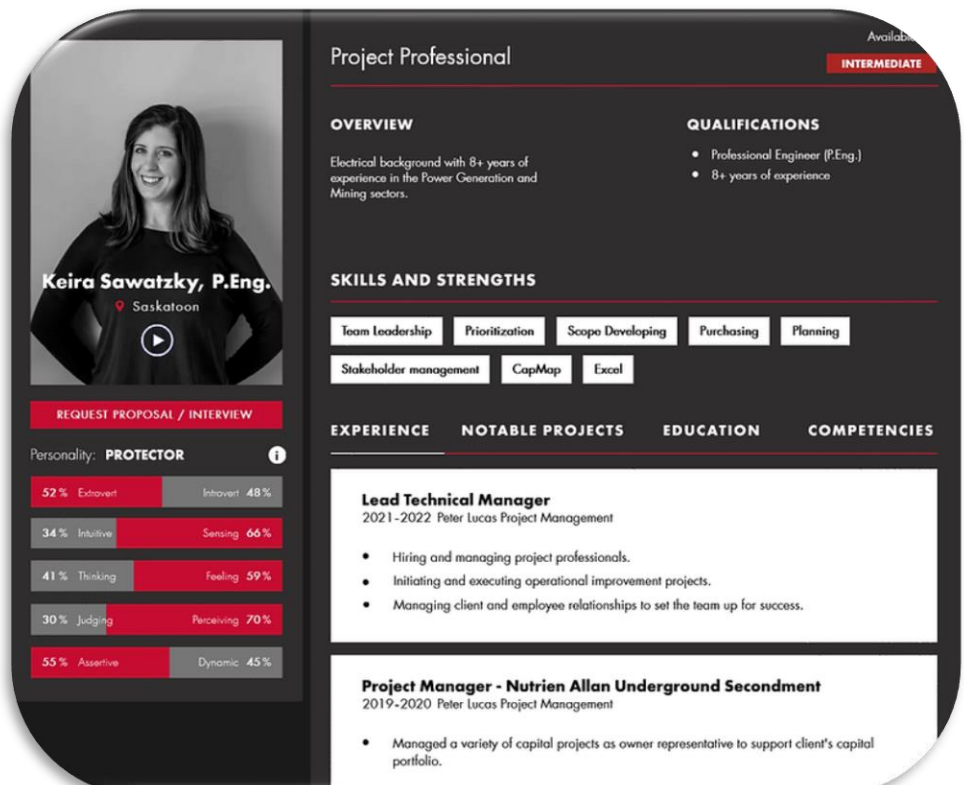

Project Professional Available

INTERMEDIATE

OVERVIEW

Electrical background with 8+ years of experience in the Power Generation and Mining sectors.

QUALIFICATIONS

- Professional Engineer (P.Eng.)
- 8+ years of experience

SKILLS AND STRENGTHS

Team Leadership, Prioritization, Scope Developing, Purchasing, Planning, Stakeholder management, CapMap, Excel

EXPERIENCE **NOTABLE PROJECTS** **EDUCATION** **COMPETENCIES**

Lead Technical Manager
2021-2022 Peter Lucas Project Management

- Hiring and managing project professionals.
- Initiating and executing operational improvement projects.
- Managing client and employee relationships to set the team up for success.

Project Manager - Nutrien Allan Underground Secondment
2019-2020 Peter Lucas Project Management

- Managed a variety of capital projects as owner representative to support client's capital portfolio.

Keira Sawatzky, P.Eng.
Saskatoon

PERSONALITY: PROTECTOR

52% Extrovert	Intovert 48%
34% Intuitive	Sensing 66%
41% Thinking	Feeling 59%
30% Judging	Perceiving 70%
55% Assertive	Dynamic 45%

REQUEST PROPOSAL / INTERVIEW



Petroleum Technology Research Centre (PTRC)

Suite 220 - 6 Research Drive
Regina, Saskatchewan S4S 7J7
www.ptrc.ca

The Petroleum Technology Research Centre (PTRC) is a non-profit R&D corporation founded in 1998 by Natural Resources Canada, Saskatchewan Ministry of Energy and Resources, the University of Regina and the Saskatchewan Research Council. The PTRC uses R&D to advance and support the recovery of Canada's rich but often difficult to access oil resources. The PTRC is committed to conducting research that will help the petroleum industry implement sustainable technologies that minimize environmental impacts, such as climate change caused by greenhouse gas emissions, while maximizing oil recovery. Many of the PTRC's projects also hold potential for minimizing water use and reducing land impacts of oil recovery.

Products & Services Include:

- Managing of the world's largest CO2 Storage Project (IEA GHG Weyburn-Midale CO2 Monitoring and Storage Project)
- Managing potentially the world's largest avoided CO2 emissions project (JIVE Project)
- Advancing enhanced oil recovery technologies through a newly established Business-Led Network of Centres of Excellence (Sustainable Technologies for Energy Production Systems, or STEPS)
- Managing Western Canada's first integrated CO2 capture, transportation, injection and storage project involving the injection of CO2 into a deep saline formation (Aquistore).
- Directing research in an investigation of fluids and their locations in the Saskatchewan subsurface (Saskatchewan Phanerozoic Fluids and Petroleum Systems)

Ran Narayanasamy, President & CEO
ranjithn@ptrc.ca
1-306-351-2726





PINTER
& ASSOCIATES LTD.

PINTER & Associates Ltd.

710A 48th Street East
Saskatoon, Saskatchewan S7K 5B4
www.pinter.ca

PINTER & Associates Ltd. is an engineering consulting company providing services in the environmental, geotechnical, mining, municipal, and safety sectors. These services are provided to private industry, institutions, government and private individuals. Their group of professionals represent nationalities from Egypt, Iraq, Poland, China, Taiwan, and Hungary.

Products & Services Include:

- Environmental consulting
- Geotechnical consulting
- Mining consulting
- Municipal engineering consulting

Lawrence Pinter, Principal
lawrence.pinter@pinter.ca
1-306-244-1710





Prairie Clean Energy

PO Box 40073
Regina, Saskatchewan S4W 0L3
www.prairiecleanenergy.com

Prairie Clean Energy Inc. is a Saskatchewan-based company that buys flax straw from Saskatchewan farmers, processes it and sells it to companies as biomass fuel.

Products & Services Include:

- Converting agricultural waste into biomass fuel for the global industrial marketplace.

Mark Cooper, President & CEO
mark.cooper@prairiecleanenergy.com
1-306-527-6854
www.prairiecleanenergy.com



Pressure Corp provides industrial facilities and the distributors and operators of pipelines a revenue-positive Scope 1 and 2 emission-reduction solution by transforming their waste pressure into clean energy. We leverage proven technology for our waste pressure power system and third-party capital to eliminate the technical and financial risk for our host customers. Pressure Corp enables our host customers to focus on their core business while adding to their bottom line and achieving a critical Environmental, Social, and Corporate Governance (ESG) objective - reducing emissions.

Products & Services Include:

- A revenue-positive scope 1 and 2 emission-reduction solution that transforms pipeline waste pressure into clean energy. They leverage proven technology for their waste pressure power system and third-party capital to eliminate the technical and financial risk for their host customers.

Jay Brown, Partner
 jbrown@pressurecorp.com
 1-306-280-3750



Gas is transported via pipelines at **high pressure**.



For industrial use, facilities drop the gas to a **lower pressure**.

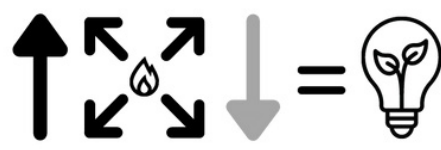

As the pressure drops and the gas expands, **wasted mechanical energy** can be transformed into **clean electricity**.





Quesnel Bros Diamond Drilling (QB Drilling)

810 Korol Way
Saskatoon, Saskatchewan S7R 0E2
www.qbdrilling.com

QB Drilling is a contract diamond drilling company serving geotechnical, mining and exploration industries across Canada. They take an environmentally sensitive approach to drilling, with the highest health and safety standards for their team members. QB Drilling is a family owned and operated business with over 60 years of combined experience in the drilling industry.

Products & Services Include:

- Drill Pad Preperation
- Remote Heli Drill Pad Preparation
- Site Clearing
- Reclamation Work
- Core Shack Facilities
- Core Cutters
- Labour Services
- Equipment rental
- Custom Core Rack Fabrication
- Skidder Services
- Remote Camp Services
- Fire Suppression
- Water Hauling
- Technical Drilling
- Wedging Installation
- APS Units
- Directional Drilling
- Split Tube Packaging
- Deep Overburden Recirculation Services

Mitch Quesnel, Logistics & Business Development

Mitch.Quesnel.Bros@outlook.com

1-306-370-3185





Rayhawk Technologies Inc.

2021 Dudley Street
Saskatoon, Saskatchewan S7M 1K9
www.rayhawk.ca

Rayhawk autonomous railcar loading solution brings the latest in technology and digitization to reality. Computer vision, machine learning, and autonomous operation all work together to identify, configure, and execute safe, reliable, and efficient opening and closing of top loading railcar equipment.

Products & Services Include:

- RAYHAWK Autonomous Lid Opening/Closing System - Executes safe, reliable, and efficient opening and closing of top loading rail car equipment; Seal Removal - This tool will cut and remove safety seals; Seal Application - This tool applies international transport approved safety seal prior to shipping to port; Cavity Inspection - Identifies if the car cavity is clean and able to be filled; and Air Knife - Uses an air knife to remove snow and debris off of the top of the rail car lid.

Muaz Sheriif, Director of Operations
muaz.sheriff@rayhawk.ca
1-306-380-2120





RESPEC Consulting Inc.

290A-2600 8th Street East
Saskatoon, Saskatchewan S7H 0V7
www.respec.com

RESPEC Consulting Inc. is a global leader in geoscience, engineering, data and integrated technology solutions, their team serves major industry sectors in mining, energy, water, natural resources, environment and infrastructure. Serving the industrial minerals, oil and gas and energy sectors, their team of professionals have earned a strong reputation for technical excellence while demonstrating respect for the environment, culture, and communities in which they work.

Products & Services Include:

- Mineral resource estimations
- Subsurface geology
- Examination of well logs, cores, geophysical data; mining engineering and materials testing; drilling services; and design and drill disposal and geothermal wells

Tabetha Stirrett, Co-President
Tabetha.Stirrett@respec.com
1-306-244-4878



Rivercity makes technology for GPS tracking, temperature monitoring and other solutions for multiple industries. For the oil & gas industry, they make a custom LoRa sensor for hydrocarbon monitoring. This soil remediation technology is innovative, clean and good for the environment.

Products & Services Include:

- GPS trackers using LoRa or cellular – used for bikes, pets, sport vehicles, trailers, and corporate asset tracking, our temperature monitoring cold-chain solution for pharmacy and grocery stores, hydrocarbon monitoring for oil and gas industry soil contamination remediation, and property monitoring for seasonal problems such as water line freezing, water leaks, or other common problems.
- Indoor Air Quality Monitor which reports on CO2, volatile organic compounds, and other ambient air issues – perfect for post-covid room control. RCI designs smart city solutions using LORA and operates a private LoRa network for its clients worldwide.

Jeff Shirley, Founder & CEO
jeff@rivercityinnovations.ca
1-306-986-8888





Rockford Engineering Works Ltd.

1734 MacRae Drive
Regina, Saskatchewan S4N 7E3
www.rockfordworks.com

Rockford has a proven track record across Saskatchewan's potash mining sector delivering successful projects both underground and on surface. These projects include upgrades and scratch-build designs for custom ROPS & FOPS, winch frames, belt reclamation, and crushing machinery. They have also delivered several successful projects for improvements to floor stabilizers & milling drums along with autonomous material handling equipment.

Products & Services Include:

- Equipment supply
- Automation
- Structural, mechanical & industrial engineering

Scott Konecsni, Marketing/Principal
info@rockfordworks.com
1-306-789-0089

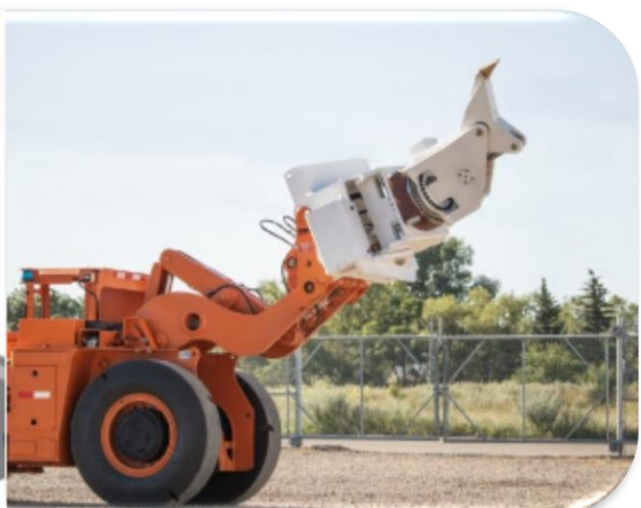
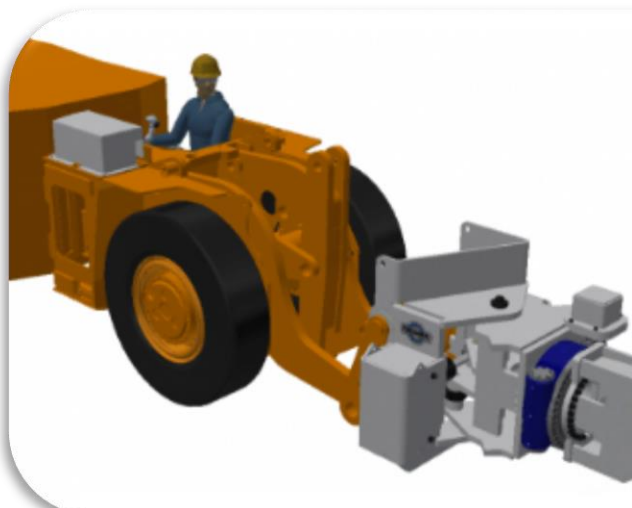
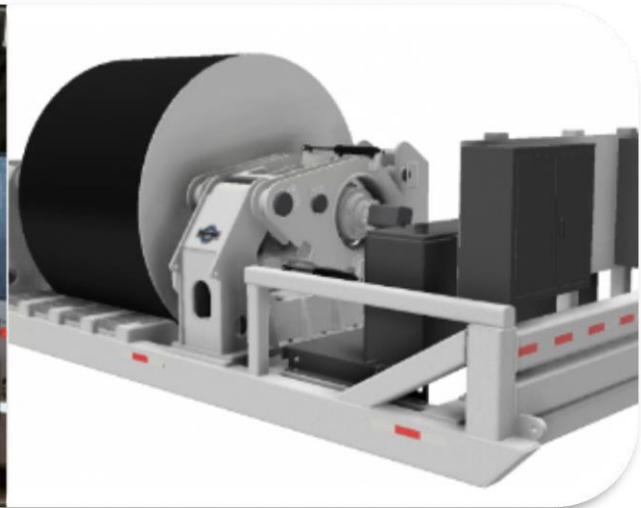



S3 Group Ltd.

2180 Oman Drive
Swift Current, Saskatchewan S9H 3V5
www.s3grouppltd.com

S3 Group Ltd. is a group of companies focused on distinctive solutions for the industrial equipment industry, including custom manufacturing and pneumatic solutions, unique wireforming services, and the Delta Flexible Harrow product. Corporately, the S3 group brings more than 50 years of experience specific to both manufacturing and to agricultural applications.

Products & Services Include:

- Custom manufacturing and pneumatic solutions
- Unique wireforming services for the farm equipment
- The Delta Flexible Harrow product.

James Willett, Business Development Manager

james.willett@s3grouppltd.com

1-306-773-0645





Saskatchewan Research Council (SRC)

Bay 2D, 820 51st Street East
Saskatoon, Saskatchewan S7K 0X8
www.src.sk.ca

SRC is Canada's second largest research and technology organization with 1,500 clients in 27 countries around the world. They provide the following services for the mining and energy sectors: geoanalytical testing, mineralogical analysis, slurry transport modelling, tailings management, acid mine drainage, plant performance, hybrid energy container solutions, remediation solutions, community engagement, reliability engineering, enhanced oil recovery, pipeline testing and many others.

Suzanne Johnston, Marketing Communications Advisor
Suzanne.johnston@src.sk.ca
1-306-933-5400



Photo credit: SRC



TEAL Electrification Systems

104-110 Research Drive
Saskatoon, Saskatchewan S7N 3R3
www.tealev.com

Engineered in Saskatchewan, Canada, **TEAL Electrification Systems** know what "extreme climate" means. Commercial electric vehicles designed from the ground up to excel from -40C to +50C. The company's groundbreaking engineering teams are creating the cutting edge of EV technology.

Products & Services Include:

- Class 6, Class 7, and Class 8 electric vehicles.

Matthew Neufeldt, Vice President
matthew@TealEV.com
1-306-850-1060

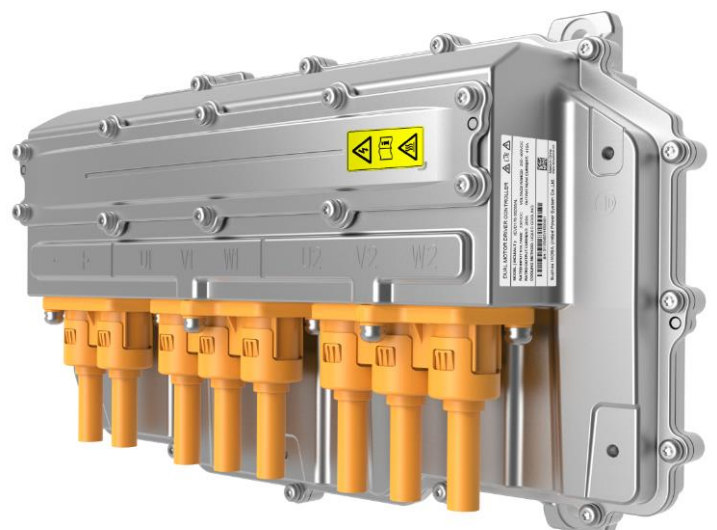



Team Power Solutions

30-318 Gladstone Crescent
Saskatoon, Saskatchewan S7P 0C7
www.teampowersolutions.ca

Team Power Solutions is an industry leader in electrical and automation solutions for agriculture, oil & gas, mining, manufacturing, pulp & paper and utilities. Our experienced team of professional engineers, technologists, project managers and product specialists deliver a full range of services to commercial and industrial customers across North America. We provide the following: underground power sleds, control panels, substations, robotics, machine learning, computer vision, automation & controls, instrumentation, electrical services and other products & services. Our RayHawk autonomous railcar loading product brings a safe and efficient way to open top-loading railcar equipment.

Products & Services Include:

- Underground power sleds
- Control panels & substations
- Robotics, machine learning, computer vision, digital applications
- Automation & controls
- Instrumentation, training, equipment remanufacturing

Brook Davis, Director of Business
Development & Marketing
marketing@teampowersolutions.ca
1-306-384-5552





Terra Modelling Services Inc.

607 Albert Ave
Saskatoon, Saskatchewan S7N 1G6
www.terramodellingservices.ca

Terra Modelling Services Inc. is a geological consultancy based out of Saskatoon, SK, Canada. While we have been in business since 2014, our staff has decades of experience across the world in a variety of commodities. This experienced team is available to tackle any geological challenge in a cost effective and timely manner. Employing decentralized office structures and effective remote working strategies, we bring innovation and new technology to bear on projects to reduce the overall carbon footprint.

Products & Services Include:

- Mineral resource exploration
- Project management
- Resource estimation
- Geological & economic modelling
- Commodity price forecasting
- Stakeholder engagement and reporting

Joe Dickson, Administration & Business Development Manager

joe.dickson@terramodellingservices.ca

1-306-292-9154





The Mosaic Company

1700-2010 12th Avenue
Regina, Saskatchewan S4P 4L8
www.mosaiccanada.com

The Mosaic Company Since forming in 2004, Mosaic has grown to be a global leader in phosphates and potash crop nutrition. They are proud to be a competitive producer with strong customer relationships, and the financial strength to invest in growth and innovation. And they've led the industry in developing high-quality performance products that help growers succeed.

Products & Services Include:

- Mining and processing of phosphate and potash minerals into crop nutrients, and then shipping via rail, barge and ocean-going vessel to their customers in the major agricultural centers of the world.

Tyler Hopson, Public Affairs Manager
tyler.hopson@mosaicco.com
1-306-523-2812



Titan Clean Energy has been a leader in pyrolysis technology and the advancement of biocarbon applications since 2008. The company is expanding into carbon-based bioplastic inputs, compostable bioplastic masterbatches, and activated charcoal for filtration.

Products & Services Include:

- Bio-based plastic additives
- Compostable bioplastic masterbatches
- Bio-based, renewable activated carbon for odour control

Michele Kiss, Manager
info@titan-projects.com
 1-306-734-2222





Vale Industries

140 Service Road | PO Box 1420
Indian Head, Saskatchewan S0G 2K0
www.valeindustries.ca

Vale Industries is a diversified steel manufacturing company located in southern Saskatchewan, Canada, with a rich history of providing successful portable and stationary solutions for industry problems. Vale Industries is continually looking to take on new challenges, whether in agricultural, manufacturing, quarrying or mining industries.

Products & Services Include:

- Grain Giant, a 6500 bushel field bin along with hopper cones for grain storage
- In their mining division, they manufacture conveyors, feeders, screens and cones.

Kendra Cruson, Chief Operating Officer
kendra.cruson@valeindustries.ca
1-306-537-4919





Wave9 Technology Inc.

P.O. Box 111
Kipling, Saskatchewan S0G 2S0
www.wave9.co

Wave9 Technology Inc. provides a combined hardware and software solution that enables conventional oil producers to improve production, reduce operating expenses, and mitigate environmental impact by automating daily site inspections using their purpose-built technology platform, coupled with AI. The company automatically informs lease operators or pumpers of issues in order to reduce site visits and allow management by exception.

Products & Services Include:

- A monitoring system that provides oilfield maintenance staff with a workflow dashboard that prioritizes interventions and feeds the 'right info at the right time' to the operator.

Joanne Cunningham, Director

joanne@wave9.co

1-306-736-3060

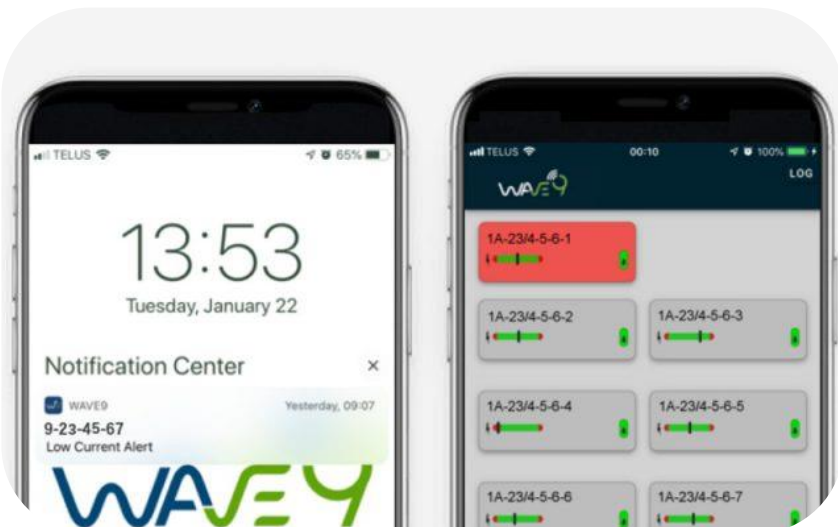



**Western
Heritage**

Western Heritage

322 Duchess Street
Saskatoon, Saskatchewan S7K 0R1
www.westernheritage.ca

Western Heritage Services Inc is a private company with offices located in Saskatoon, Saskatchewan; Calgary, St. Albert and Grande Prairie, Alberta. For over a decade our staff have been involved in hundreds of heritage studies throughout Canada.

Products & Services Include:

- Satellite imagery
- opusTrack
- opusSchedule software
- EFMP software
- Archaeology & cultural heritage management
- GPR services
- Image interpretation services
- GIS mapping services
- UAV mapping
- Inspection services

Jim Finnigan, President
info@westernheritage.ca
1-306-975-3860





WRT Equipment Ltd.

818 - 43rd Street East
Saskatoon, Saskatchewan S7K 3V1
www.wrtequipment.com

WRT Equipment Ltd. has been serving the road and mining industries since 1975. They manufacture and distribute construction equipment products used by contractors in road related construction and in the mining industry.

Products & Services Include:

- Construction equipment products
- Conveyors
- Crushers
- Asphalt plants
- Compaction equipment and more

Kelsey Van der Gracht, Marketing & Advertising
kvandergracht@wrtequipment.com
1-306-244-0423





Saskatchewan Trade and Export Partnership (STEP) Inc., is a member-driven, non-profit corporation dedicated to increasing Saskatchewan's export activities and raising awareness of Saskatchewan's distinct products and services.

Linking Buyers with Saskatchewan Suppliers:

STEP is your direct connection to a wide range of Saskatchewan's high-quality products and services: agriculture & food, biotechnology, agricultural & industrial equipment, natural resources, professional services, building products, environmental solutions...and the list goes on. As a complimentary service for you, STEP can help match you with Saskatchewan exporters who meet your needs.



Scan to view our STEP Member Sector Directories

Regina Office
#320 - 1801 Hamilton Street - Box 1787
Regina, Saskatchewan S4P 3C6
Canada
+1.306.787.9210

Saskatoon Office
#400 - 402 21st Street East
Saskatoon, Saskatchewan S7K 0C3
Canada
+1.306.933.6551

www.sasktrade.sk.ca inquire@sasktrade.sk.ca